

CONFEZIONATRICE VERTICALE MODELLO S-600i

itecma
Packaging Machines & Services

*Vertical packaging machine
Model S-600i*



La confezionatrice S-600i è una macchina automatica a movimento intermittente per il confezionamento a cuscino di prodotti sfusi.

E' disponibile con vari sistemi di dosatura: con pesatura a canali vibranti o tappeti, con dosatori volumetrici, con dosatori a coclea per prodotti polverosi, con nastro di carico prodotto.

A richiesta possiamo sviluppare linee di confezionamento complete.

Intermittently moving vertical packaging machine S-600i is an automatic machine for the pillow pack of bulk products typically with material films heat-sealed taken from coil.

Available with various dosing systems: with channel weighing vibrating or carpeting, with volumetric dosing machines, with screw dosing for powered products, with product loading belt.

On request, all kinds of packaging lines and automations can be developed, complete plants with conveyor belts, hot printer applications, for a complete and functional packaging line.

itecma

www.itecma.it

Via Luigi Cazzola, 37 | 36015 Schio (VI) | Italy

Tel. +39 392 7857253 | Email: info@itecma.it

CONFEZIONATRICE VERTICALE MODELLO S-600i

itecma
Packaging Machines & Services

*Vertical packaging machine
Model S-600i*

Caratteristiche principali:

- Funzionamento pneumatico
- Touch-screen interfaccia operatore
- Prodotti confezionabili:
formaggi freschi, mozzarelle, frutta secca,
cereali, biscotti, snacks, surgelati, caffè, riso,
zucchero, sale, ecc.
- Larghezza max bobina 600 mm
- Velocità max 50 confezioni/min.
- Potenza installata 2500 watt
- Alimentazione 400V – 50 Hz – 3Ph+N
- Funzionamento con PLC

Optional:

- Fotocellula per stampa centrata
- Stampatore a caldo
- Immissione liquido di governo
- Immissione gas inerte
- Pesatrici e dosatori

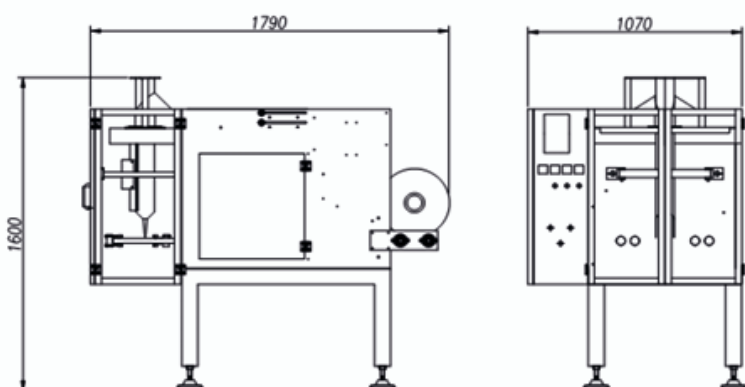

Technical features:

- *Pneumatic function*
- *Touch-screen operator interface*
- *Products to be packaged:
fresh cheeses, mozzarella, dried
fruits, cereals, biscuits, snacks,
frozen foods, coffee, rice, salt,
sugar, etc.*
- *Max coil width 600 mm*
- *Max speed 50 bags/minute*
- *Installed power 2500 watts*
- *Power supply 400V – 50Hz –
3Ph+N*
- *Functional with PLC*

Optionals:

- *Photocell for centered printing*
- *Hot printer*
- *Liquid input government*
- *Inerte gas input*
- *Weighers and dosers*

itecma

www.itecma.it

Via Luigi Cazzola, 37 | 36015 Schio (VI) | Italy
Tel. +39 392 7857253 | Email: info@itecma.it